

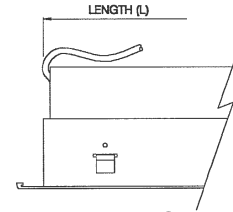

- Smooth, clean lines provide the designer with an appealing washer luminaire
- The construction of this luminaire permits many lamp alternatives
- This unique system may be plaster fixed or installed into standard ceiling tile applications
- Supplied with a standard white asymmetric reflector, satin finish or specular aluminium finish
- Plaster fitting supplied with extruded trim frame and fixing brackets
- Superb uniformity and distribution achieved with this efficiently designed reflector

DIMENSIONAL

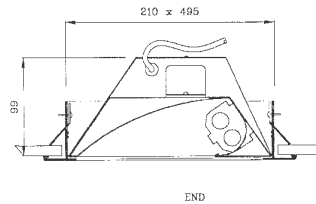

Body Lengths

INSTALLATION

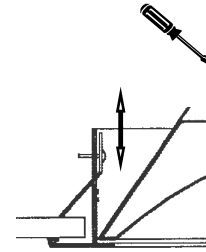

LAMP

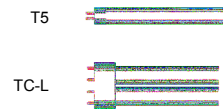

SPECIFICATION

Part Reference	Lamp	Diffuser	Length
Qulite-PM-FITR PL 136	TCL	-	495mm
Qulite-PM-FITR PL 155	TCL	-	595mm
Qulite-PM-FITR PL 255	TCL	-	1190mm

PHOTOMETRICS

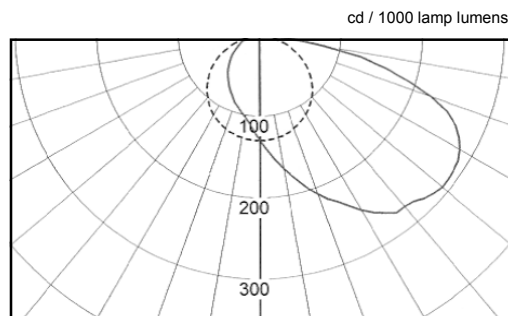

Dotted line 0 Degrees  
Solid line 90 Degrees

1/36 TC-L Lamp